



PR445S WEIGH CONTROLLER

## Features

- Load Cell Weighing with Pushbutton Calibration accurate to 16,000 divisions (65,000 divisions internal resolution)
- Automatic Ingredient Weighing and Discharge through a Weigh Hopper, Process Vessel or Loose Container Weigh Platform, up to 6 ingredients.
- Single or Multiple Recipe Operation, up to 50 recipes.
- Two speed feeding.
- Automatic In-Flight compensation.
- Timer/Interlock options for control of Mixing, Heating and other process operations.
- Trip Level Options
- Serial Communications with computers and PLC's.

## Description

The PR445S is a single weigher, multiple ingredient, weigh controller that may be used in a variety of batch process applications.

It operates from stored recipe data entered and edited through its front panel. Individual recipe lines, sequentially executed, define single ingredient weighments, timer/interlock and discharge functions. Each line consists of the following data items: Instruction, Output selection, and Target (if applicable).

Recipe execution can be started, stopped and when necessary reset, by using the three digital inputs either under automatic control from other equipment or from external push-buttons.

In addition to recipe instructions, some outputs may be configured to alternative control functions as follows:

High and Low trips, common Fast Feed.

### Technical Data

#### Model No:

PR445S AC Powered.  
Add suffix 'D' for DC powered option.

#### Power Supply:

Universal fused power supply 85-264V AC or 9-36V DC. Internal Mains Fuse fitted.  
Power consumption 10VA.

#### Load Cell Excitation:

10V DC @ 125mA max, 1 to 4 x 350 ohm load cells may be connected in parallel, 4 or 6 wire for volt drop compensation in long cables.

#### Load Cell Input Range:

0-20mv min  
0-2.5v max

#### Load Cell Input Filter:

0.2 to 20Hz active low pass.

#### Accuracy:

Up to 16,000 +/- 0.5 divisions.  
16 bit 1:65,000 internal resolution.

#### Display:

14mm high character green LED.  
Selectable update rate and minimum increment.

#### Digital Inputs:

100-240V AC (or 18-30V DC for PR445S-D)

#### Relay Outputs:

Max. 240V AC or 30V DC 5A rated contacts.

#### Serial Interface:

RS232 Full Duplex

#### Enclosure:

Panel mounting DIN case, IP65 sealed front.  
144mm wide x 96mm high x 132mm deep.  
Panel cut-out 138mm wide x 92mm high

#### Environment:

Operate 0-50°C, 20-80% RH non-condensing.  
Storage -40 to 80°C

## Recipe Example

Line	Instruction	Output	Target	Function
0	W	1	300	Weigh 300kg of ingredient 1
1	W	2	200	Weigh 200kg of ingredient 2
2	W	3	600	Weigh 600kg of ingredient 3
3	C	5	180	Set output 5 on for 3 mins
4	T	6	60	Pause for 1 min with output 6 on
5	D	7		Discharge weigher
6	*			
7	*			

## Recipe Instructions

Parameter	Name	Definition
*	None	Null instruction. Performs no action.
W	Weigh	Weigh function. The output specified is energised until the NET is > TARGET - IFC
T	Timer	Timer function. The output specified is energised until the time specified has elapsed
I	Timer with Interlock	As above but the timer will hold if the interlock input is OFF
C	Continuous Timer	As Timer, but recipe execution will move onto the next line. i.e. the timer will run in the background.
D	Discharge	Discharge function. The discharge output will be energised until the weight has fallen below the discharge band, and remains below the discharge band for the discharge time

## Batch Counting

In continuous repeat batching applications, a batch counter function can be used to set the total number of batches to be produced.

## Typical Application

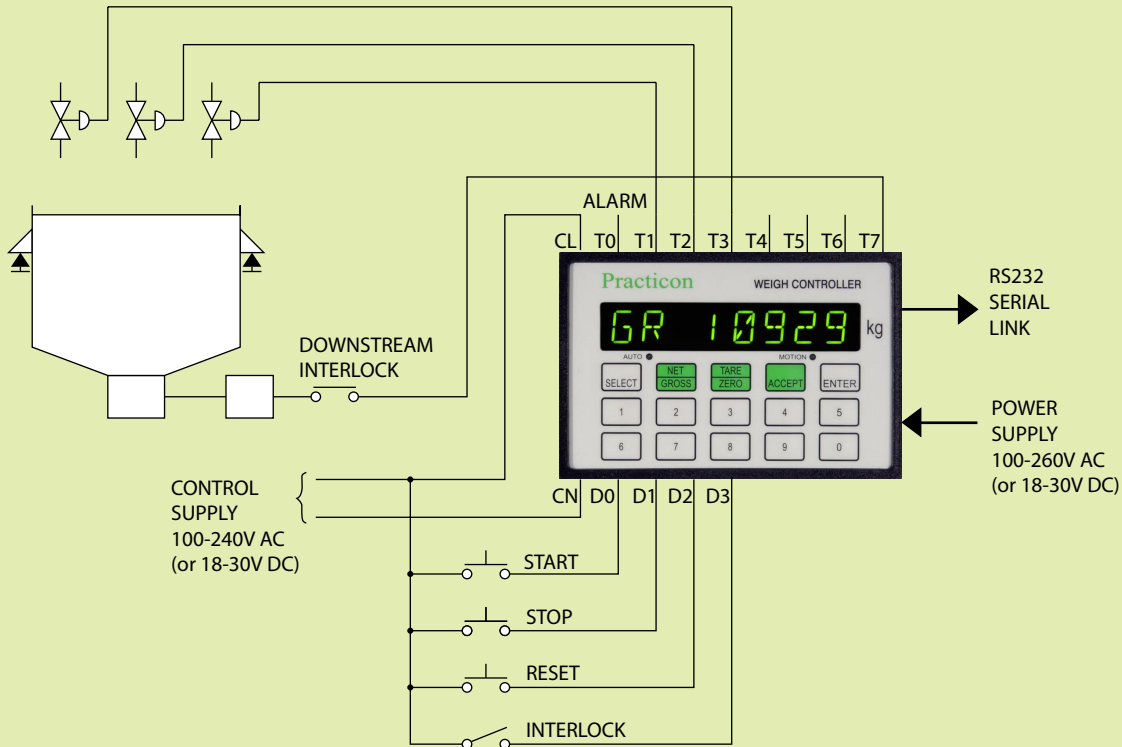

## Non-Recipe Functions

The digital outputs T1 to T6 may be configured to other functions not driven by the recipe instructions as follows

	Name	Function
H	High Trip	ON if Gross Weight is above the setting
L	Low Trip	ON if Gross Weight is below the setting
F	Fast Feed	Cuts OFF when NET Weight within the FC setting of the target

## Alarms

Output T0 is set ON when a tolerance alarm message is shown on the display ie OV WGHT, or UN WGHT.

## Plant Interface

Digital inputs can operate from 110V - 240V AC nominal control supplies, or 18V - 30V DC in the case of the DC powered version PR445S-D. Digital Outputs are volt - free relay contacts with one common connection and can switch up to 240V AC or 30V DC loads.

The PR445S connects with a single set of 1 to 4 strain gauge load cells to which it supplies 10V DC excitation. It amplifies and conditions the resultant signal to produce a calibrated weight reading to an accuracy of 1 part in 16000 with an internal resolution of 1:65000.

## Printed Reports

The RS232 serial output transmits batch reports to a printer or computer, one line per batch, with usage total and new header whenever the recipe is reselected.

## Batch Report Format

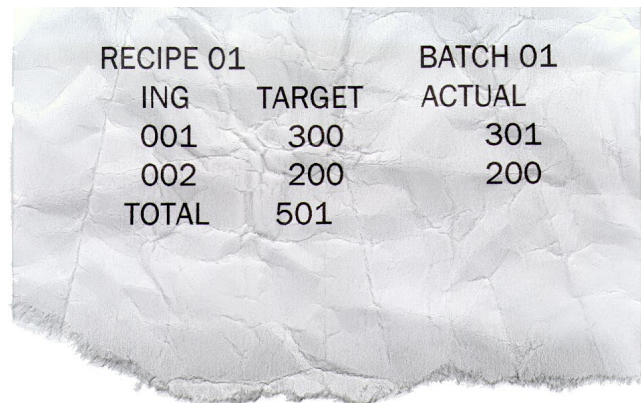

Supplied by:



**Practicon Limited**

Chapel Lane, Rode Heath, Stoke On Trent, ST7 3SD, UK  
Tel: +44 (0)1270 876211 Fax: +44(0)1270 878887  
Email: sales@practicon.co.uk Website: www.practicon.co.uk